



**GENESIS-40**  
**GENESIS-55**  
**GENESIS-75**

*LONG RANGE THERMAL  
IMAGING RIFLESCOPES*

**OPERATION MANUAL**

*Software Version 53.0.37*

**IMPORTANT:** Please read this manual in its entirety **PRIOR** to using this device!



**WARNING: NEVER POINT THIS DEVICE DIRECTLY AT THE SUN OR ANY FIRE / HEAT SOURCE WITH TEMPERATURE OF OVER 500C/930F! DOING SO WILL PERMANENTLY**

**DAMAGE THE THERMAL SENSOR AND WILL VOID ANY WARRANTY CLAIMS! SEE PAGE-19 FOR MORE DETAILS AND FOR VERY IMPORTANT CARE WARNINGS!**

## **THERMAL IMAGING:**

Let's try to understand how this device works and what it can and cannot do:

1. Your thermal device works on the principle of detecting infrared radiation, also known as energy. Instead of operating in a visible light spectrum of 400-700nm (such as regular binoculars or scopes), thermal imagers detect waves as high as 17,000nm or 17 $\mu$ m, which are beyond our capability to observe with naked eye. The infrared signal is received by the thermal device and is then converted into an electrical signal by the thermal sensor (called microbolometer), located inside the unit and that electrical signal is then displayed on the micro display located near the ocular (eyepiece).

2. Your device operates with batteries. Unlike a daylight scope, where you see the image due to light traveling through the glass and the prisms, the thermal imaging device works by projecting the image onto a screen. While the thermal sensor is the crucial component of any thermal device, the image display quality is also very important to have the best possible image clarity and widest field of view. Since the image is projected on the screen, it has certain limited resolution...so please do not expect your device to provide the same crystal clear and full-color image as you would see through your daylight scope. The main advantage of this thermal device is that it detects heat signatures in the conditions where seeing your target is virtually impossible with your naked eye.

## OPERATION:

*GENESIS-40 (same but smaller front lens); GENESIS-55 (shown) & GENESIS-75 (same but with larger front lens)*

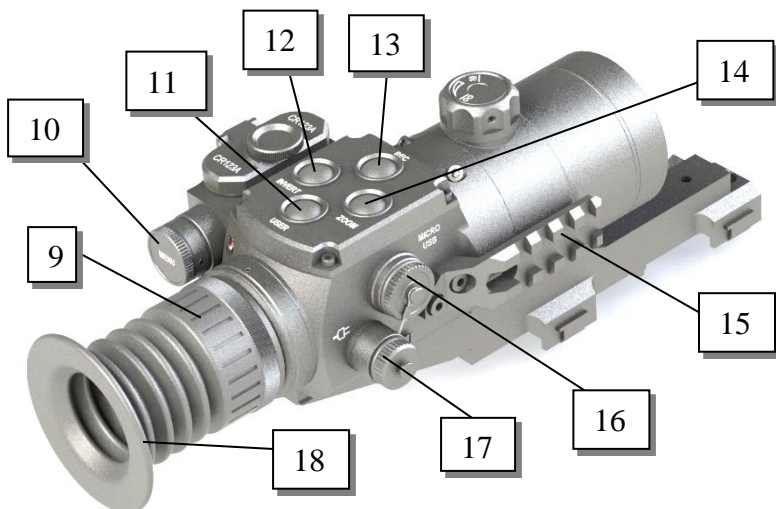
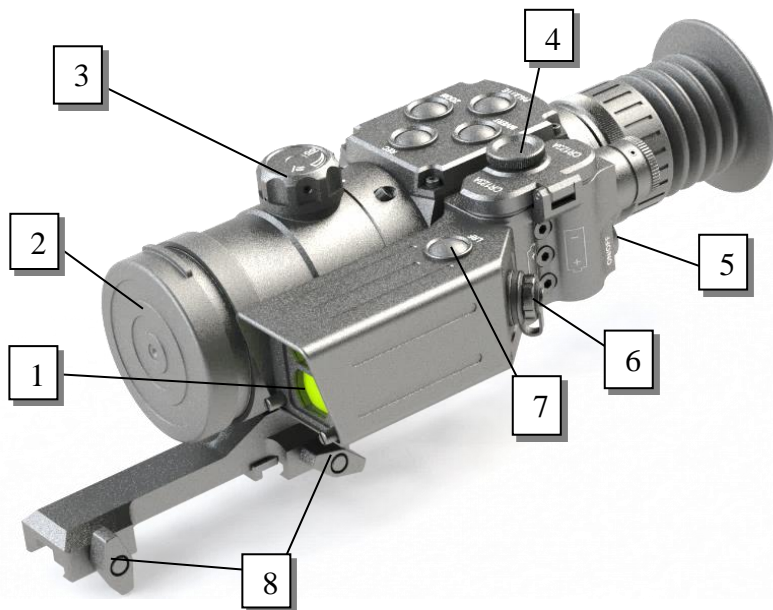

## GLOSSARY

- 1 – Laser Rangefinder Lens
- 2 – Objective Lens (Lens Cover)
- 3 – Distance Focusing Knob
- 4 – Battery compartment Cover

- 
- 5 – Power ON/OFF (Standby) (User-2) Button**
  - 6 – Laser Rangefinder Remote Pad Connector**
  - 7 – Laser Rangefinder ON / Range Button**
  - 8 – Weapon Mount Screws**
  - 9 – Ocular Focusing Ring**
  - 10 – Super Controller / Menu Access**
  - 11 – USER Programmable Button**
  - 12 – INVERT Button**
  - 13 – Video Recording / Photo Button**
  - 14 – ZOOM Button**
  - 15 – Accessory Rail**
  - 16 – Micro USB-C Connector**
  - 17 – External Power Supply Connector**
  - 15 – Rubber Eyecup**

## **INSTALLING THE BATTERIES:**

---

Your thermal scope operates on commonly available 3V Lithium batteries, CR123-type. You need 2 batteries to operate the device. Rechargeable batteries are OK, but their peak voltage cannot exceed 4.2V each.

To install the batteries, unscrew the battery compartment cover (4) and install the batteries according to the diagram. Once the batteries are inside, replace the cover and tighten.

## **TURNING THE UNIT ON AND OFF:**

---

Your thermal scope has a push Power button (5). To turn the unit ON, first remove the objective lens cover and push the Power Button (5) for a little over one second. Look through the eyepiece – the unit will become operational within approximately 4-5 seconds. To turn the unit OFF push the same button for approximately 2 seconds. Please note that the power button comes programmed from the factory to work in the Standby mode, when Power Button is pressed momentarily during operation. The unit remains on, but the image display will be turned off. The red LED power indicator will remain lit during the standby mode. To turn the display back on, press the Power button momentarily again. See Page-10 for information on how to turn your ON-OFF button into a User-Programmable button. Always replace the objective lens cover after the unit is turned off and is no longer in use.

## **FOCUSING THE UNIT:**

---

To obtain the sharp image, you must first rotate Ocular Focusing Ring (9) in either direction, until you notice in which position the image is at its best. Since you are looking at a display, it will be easier to adjust the ocular by simply focusing your attention on the displayed letters and numbers. After that, rotate the Distance Focusing Knob (3) also until the image is at its best. You may have to repeat the process

again, until the image is sharp and clear. Once the clear image is obtained, you no longer need to adjust the Ocular Ring, just rotate the Distance Focusing Knob to adjust the distance to the object you are viewing.

## **MOUNTING THE SCOPE:**

To mount the unit onto a weapon, you must have either a Picatinny Rail, or a Weaver Rail present on your gun. Attach the included mount with the three screws onto the baseplate of the scope. Use Loctite blue to secure the screws. Align the front and rear mounting plates of the scope mount with the rails, so that scope mounting indents are inside the rails and slightly tighten the screws. Make sure your eye can comfortably see inside the rubber eyecup, as the eye-relief in this scope is augmented by the long suction cup (18), which shields your eye from any possible recoil damage, therefore your aiming eye must be positioned exactly at the end of the rubber cup and not at a distance, as you would normally do in daylight scopes. Once the ideal position is obtained, if you intent on keeping this scope permanently on the gun, we recommend using Loctite blue to secure the scope mounting screws (8) in place.

## **SUPER CONTROLLER FUNCTIONS:**

Your thermal riflescope comes with a unique Super Controller (10), which allows for nearly instant image adjustment to the best possible brightness and clarity without having to enter the menu settings. This feature is extremely useful when atmospheric conditions change rapidly, especially during high humidity and/or rapid temperature changes.

The super controller has the following sequence when short-pressed:

1. IMAGE GAIN (**GAIN**)
  2. DISPLAY BRIGHTNESS (**BRGT**)
  3. SENSITIVITY (**SENS**)
  4. IMAGE DETAIL ENHANCEMENT (**IDE**)
- **To adjust the IMAGE GAIN**, rotate the Super Controller either clockwise or counterclockwise while viewing the image – you will see word **GAIN** and either positive or negative number appear on the bottom left corner of the image display. There are 10 negative and 10 positive Gain levels and a Zero level. Lowering the Image Gain will allow for better facial and detail recognition. Increasing the Image Gain will allow for better target detection and recognition of surroundings, such as houses/buildings, trees and bushes and so on, allowing you to better see the target surroundings and to better orient in the terrain.
  - **To adjust the Display Brightness level** short-press the Super Controller once and letters **BRGT** will appear in the display

– you can now rotate the same switch and Display Brightness will change. There are 30 levels of display brightness. During nighttime use, brightness level is optimal between 10 and 20, depending on the ambient conditions. Keep in mind that higher brightness levels drain the batteries faster.

- **To adjust the Thermal Sensitivity (Sensor's Brightness Output)** short-press the GAIN switch twice and letters **SENS** will appear in the display – you can now rotate the same switch and Sensitivity will change. There are 40 levels of sensitivity (min sensitivity is 40 and max is 80)
- **To activate the Image Detail Enhancement (IDE)** short-press the GAIN switch three times and letters **IDE** will appear in the display – you can now rotate the same switch and image details will be enhanced. There are 7 levels of enhancement and a Zero level. Each IDE level incrementally increases the level of the detail, similar to the TV resolution upscaling, allowing user to greatly enhance the image resolution and level of image detail. This feature is especially useful during high humidity, where normally level of image detail is poor. It is also useful when observing object at long distances and when utilizing Zoom function.

## DEVICE MENU NAVIGATION – IMPORTANT!



1. When long-pressed, the Super Controller activates the main menu (**M**).
2. On Once Menu is activated, rotating controller will highlight each menu chapter from top to bottom.
3. Once the particular menu chapter is highlighted in green color, the selection can be initiated by short-pressing the Super Controller, after which the menu chapter will highlight in red color. Now rotate the Super Controller in either direction to select desired setting. Confirm the setting by short-pressing the Super Controller, which will change the highlight from red back to green color. Now the chapter is out of the selection mode and next menu chapter can be selected by rotating the Super Controller.
4. Exit back to the main menu by either short-pressing or long-pressing the Super Controller (depends on the menu function)
5. Main menu can then be turned off by long-pressing the Super Controller again, or, alternatively the menu automatically turns off after 15 seconds of inactivity.

## **Main Menu Selections (from top to bottom):**

### **1. User Profile**

*There are 3 Custom User Profiles, which can be saved and deployed when necessary. Each user profile covers variety of settings, such as Color Palette, type of reticle, color of reticle, sensor gain and sensitivity, display brightness, Image Detail Enhancement and other settings. We recommend finding best settings for a particular terrain or weather conditions and then saving it as a User Profile, so that next time you are in a same/similar terrain or weather pattern, you can quickly activate the settings without having to adjust them all individually. There are 3 customized User Profiles and 3 factory pre-set profiles (**Woods, Mountains & City**). Customized profile settings are automatically saved once adjustments are made and in order to start a new profile enter the main menu and switch the User Profile from 1 to 2 or 3, then perform new adjustments according to your preference.*

### **2. Color Palette**

*This setting allows user to select the image Color Palette. Please refer to page-13 IMAGE POLARITY INVERSION / COLOR PALETTES for more information*

### **3. Palette on button “USER”**

*This menu setting allows you to select which color palette will turn on when USER button is pressed (this menu option is only shown when USER button is actually programmed to switch color palette (see USER Button Function for more information))*

### **4. Thermal Image Gain**

*See page-5 for GAIN adjustment. NOTE: this function is available via Super Controller and is normally adjusted without getting into Menu.*

### **5. Display Brightness**

*See page-6 for BRGT adjustment. NOTE: this function is available via Super Controller and is normally adjusted without getting into Menu.*

### **6. Thermal Sensitivity**

*See page-6 for SENS adjustment. NOTE: this function is available via Super Controller and is normally adjusted without getting into Menu.*

### **7. Image Detail Enhancement (IDE)**

*See page-6 for IDE adjustment. NOTE: this function is available via Super Controller and is normally adjusted without getting into Menu.*

### **8. Image Polarity Inversion**

See page-13 for IMAGE POLARITY INVERSION. NOTE: this function is available directly via INVERT Button (12) and is normally done without getting into Menu.

## **9. Super Contrast Display Mode**

*This setting allows user to enter the Super Contrast mode, which is helpful during extremely humid weather conditions, where targets will appear “washed out” against the background, as well as during the situations where target heat is waning. This is especially useful during search and rescue operations where quick location of the heat source may be very important, as well as when tracking wounded or expired game. Please note that Super Contrast Mode is only seen on the scope’ image display, therefore, if you are recording video in the Super Contrast Mode, during video recording playback only normal mode will be visible. Super Contrast Mode can be utilized with any of the 10 color palettes.*

## **10. Reticle Profile**

*There are 7 profiles allowing you to zero your scope at various distances (for example you can save Profile-1 as zeroed at 100yds / Profile-2: 300yds etc.), or zeroing your scope for various distance and different cartridge (for example Profile-1: Match Grade 120gr GMX bullet at 100yds / Profile-2 100gr SST soft point bullet at 200yds etc.). Reticle profile automatically saves the reticle type, reticle color and all windage and elevation adjustments performed. To perform different adjustment, enter Menu, select Reticle Profile and switch to Profile-2, then Profile-3 and so on. Each profile, once selected will automatically save all adjustments performed with the reticle.*

## **11. Reticle Type**

*There are 5 types of reticle available. Rotating the Super Controller will change the reticle type. Once desired reticle is selected, short-press the Super Controller to exit to main menu. See page-14 for more details.*

## **12. Reticle Color**

*There are 6 selectable reticle colors, allowing user to select best color to contrast the target, depending on the target temperature and color palette. See page-14 for more details*

## **13. Reticle Brightness**

*There are 8 selectable levels of reticle brightness (1 lowest and 8 highest), allowing user to select best reticle brightness according to the ambient conditions / display brightness. **Higher levels of reticle brightness may contribute to burn marks, common with OLED displays, when used over a long period of time.** We recommend setting everyday reticle*



brightness to levels 1-5 to maximize the longevity of the OLED display and only use higher brightness levels as necessary.

#### **14. Zero the Scope**

*This menu setting allows for correcting the windage and elevation adjustments for bullet's point of impact. See page-14 ZEROING THE SCOPE for complete instructions.*

#### **15. USB Data Transfer to PC**

*This setting allows you to transfer the video recorded data through USB connection to your computer or tablet. Enter this selection by short-pressing the Super Controller. Please note that this mode disables most of the scope functions in order to allow the most reliable USB connection. See more details on page-17*

#### **16. Wi-Fi (if equipped)**

*This menu setting allows user to turn Wi-Fi function on or off. If equipped, please refer to page-17 for details on how to activate and connect to a smart device via Wi-Fi.*

#### **17. Video Record Mode (Video Start Mode)**

*This setting allows you to select how soon video recording starts. There are two options:*

- 1. **Normal start** – the video recording module is completely off until you press REC button (13), then the module starts, taking approximately 15-20sec between pressing the REC button and actual start of video recording. This mode allows you to save the batteries when video recording is not desired, such as simple terrain orientation.*
- 2. **Quick start** – the video recording module starts as soon as you power the scope and enters the standby mode. When REC button is pressed, video recording starts within 5 seconds during the first recording and within 3 seconds thereafter. This mode allows you to start recording almost instantly and is useful when frequent shots are taken during hunt, or any time when video recording is frequently used. Please note during this mode additional battery power is used.*

#### **18. Date and Time Stamp Position**

*This setting allows user to select the on-screen position of the date and time during video recording. Four positions are available: Right Down – Left Down – Right Up – Left Up in addition OFF position is available, which removes date/Time Stamp from video recordings.*

#### **19. Auto Bad Pixel Correction**

*This function allows the scope computer to automatically correct any bad pixel. For manual bad pixel correction, please*

refer to the next menu function and also to the BAD PIXEL CORRECTION instructions on page-16.

**IMPORTANT:** DURING AUTO OR MANUAL BAD PIXEL CORRECTION PROCESS YOU MUST KEEP THE LENS COVER ON AT ALL TIMES AND WE RECOMMEND PLACING A DARK TAPE OVER THE PINHOLE IN THE LENS COVER. THIS IS NECESSARY FOR A COMPLETELY UNIFORM DARK SCREEN DURING THE PROCEDURE.

## 20. Manual Bad Pixel Correction

*This function allows the user to correct any bad pixel that may appear during the use of the device, without having to return the scope to the factory. Please see page-16 for BAD PIXEL CORRECTION instructions*

## 21. “ON-OFF” Button Function

*This unique function allows user to select which function the ON-OFF button (5) can control instantly **when pressed momentarily**. You may choose to assign a number of functions to this button, for example changing the User Profiles, or type of aiming mark (reticle) or changing the color of the reticle, or assigning a Super Contrast Mode. You may assign the function to this button at any time and there are no limits to the number of times the user can re-assign this function. Factory default function for this button is Display ON-OFF (Standby). Please note that long-press*

## 22. “USER” Button Function

*This unique function allows user to select which function the User Button (11) can control instantly. You may choose to assign a number of functions to this button, for example changing the User Profiles, or type of aiming mark (reticle) or changing the color of the reticle, or assigning a Super Contrast Mode, or instantly changing the Color Palette. You may assign the function to this button at any time and there are no limits to the number of times the user can re-assign this function.*

## 23. LRF Reading Position

*This setting allows user to select where on screen the Laser Rangefinder reading is displayed. Two positions are available: Up and Down.*

## 24. Distance Unit

*This function allows to switch Rangefinder distance reading between Meters and Yards. NOTE: depending on the software version, if you ever perform Settings Reset (Menu item 36) this function may disappear from the Menu until you activate the Laser Rangefinder for the first time by pressing LRF Button (7)*

## 25. Status Bar Position

*This setting allows user to select where on screen the status bar is displayed. Two positions are available: Up and Down*

## **26. Status Bar Delay Time, s**

*This setting allows user to select whether the status bar can remain visible constantly, or will be turned off after a short delay. Delay time is available between 2 and 7 seconds (in 1 second increments), as well as OFF position, which allows the status bar to remain visible constantly. NOTE: scope is shipped with status bar hide time in OFF position.*

## **27. Menu Position**

*This setting allows user to select on screen display menu position. 3 settings are available: Up / Center / Down*

## **28. OSD Transparency**

*This setting allows user to select the transparency of the On Screen Display Menu, as well as reticle and status bar transparency. 5 levels of transparency are available along with Zero transparency. Each higher level of transparency makes menu more transparent when activated. **Higher levels of transparency prevent developing burn marks, common with OLED displays, when used over a long period of time.** We recommend setting transparency level on 3 or higher to maximize the longevity of the OLED display.*

## **29. Auto Power OFF, minutes**

*This setting allows the scope to automatically power down after a certain time of inactivity. Default setting is OFF, meaning the scope will continue to work until manually shut down, however you can choose an option when the scope will power down by itself if you have not pressed any button between 10 minutes and 60 minutes (in 10 minute increments). This feature is automatically disabled when active video-recording is in process.*

## **30. Date Set**

*This setting allows user to set the date, as it would appear on the video recording stamp. The date appears in YYYY-MM-DD sequence. Rotate the Super Controller to change the year, then switch to month by short-pressing the Super Controller and repeat the same for day. Once day is adjusted, short-pressing the Controller returns to the main menu.*

## **31. Time Set**

*This setting allows the user to set the time, as it would appear on the video recording stamp. Switch between HH:MM:SS by short-pressing the Super Controller and adjust the time by rotating the Super Controller. Please note the time is displayed in military units, so 1pm = 13:00, 6pm = 18:00, 11pm = 23:00 and so on.*

### **32. Clear Video Record Storage**

*This selection allows you to format the memory card and erase all video recordings from the card without connecting device to the computer. To protect from accidental erase, once this feature is selected, the device will ask you to confirm this selection within 5 seconds by short-pressing the Menu button, otherwise the function will not activate.*

### **33. Language**

*This setting allows user to select menu language. 4 languages are available: ENGLISH – GERMAN – SPANISH - RUSSIAN*

### **34. Version of the Video Rec. Module**

*This selection displays the current software version for the Video Recorder Module and cannot be edited. This information may become useful if customer support is required.*

### **35. Software Version**

*This selection displays the current main software version and cannot be edited. This information may become useful if customer support is required.*

### **36. Settings Reset**

*This selection allows user to reset all settings to factory levels. We do not recommend using this function, unless you feel that the scope is not functioning as it should. If this happens and you need to reset the settings to factory levels and after the reset you have any troubles navigating the menu, please e-mail us at: [FullMoonOptics@gmail.com](mailto:FullMoonOptics@gmail.com) or call us at 478-954-2721 with any questions you may have.*

## **IMAGE ZOOM FUNCTION:**

The standard (optical) magnification of your thermal riflescope is 3.5x (2.5x on model GENESIS-40 / 5.0x on model GENESIS-75) (you will see the objects approximately 3.5 times closer than if looking with the naked eye). It is possible to increase the magnification by applying a digital zoom function. There are two zoom levels (2x and 4x) meaning your combined magnification will be either 7x or 14x. (10x and 20x on the G-75) To utilize zoom function press the ZOOM Button (13) once to achieve 2x zoom (7x (10x) magnification) or twice to achieve 4x zoom (14x (20x) magnification). To return to standard optical image press the Zoom Button once more. Please note the image display will show either 1x, 2x or 4x, depending on how many times you press the Zoom Button.

## **IMAGE POLARITY INVERSION / COLOR PALETTES:**

It is possible to change the way the heat signatures are displayed – the default image is “WHITE HOT” meaning the heat signatures will

appear in white or light color with most of the background appearing in black or dark color. You may switch (invert) this setting by pressing the INVERT Button (12) once and then heat signatures will appear in dark color “BLACK HOT” on otherwise light color background. In addition, the unit also has options of 10 color palettes, each with invert option, which highlight heat signatures in various colors. To change between the Color Palettes, long-press the Super Controller (10) to enter main menu, then rotate Super Controller until word “Palette” is highlighted. Then short-press Super Controller to select this function and then rotate the Super Controller to switch between various Color Palettes. There are 9 color palettes + default black & white mode. You should try each color setting to see which one renders images best during various atmospheric conditions and humidity levels, as well as for the particular task at hand. Once finished selecting the color palette, short-press the Super Controller to return to the main menu and then long-press the same Controller to exit the menu. Your color and invert setting is automatically saved and will appear next time you turn on the device.

## **USING LASER RANGEFINDER:**

Your thermal riflescope comes with fully integrated Laser Rangefinder allowing you to accurately and quickly measure the distance to the viewing object up to approximately 700m (760yds). Laser Rangefinder To measure the distance you must first activate the feature by pressing once the Rangefinder Button (7). You will see the red shutter box appear in the display. At this point you can aim at the viewing object and press the Rangefinder Button once more while aiming – the distance will appear after a brief pause and it will look like this “25m”, which is displayed in either Meters (1m=1.09yds), or Yards. You can switch to display distance in either meters or yards through the main menu. Should you see “---” message it may be because you are aiming at an object that is either beyond 700m (763yds) or too close (closest measured range is approximately 5m). The rangefinder function will be disabled after approximately 5 seconds of inactivity.

**IMPORTANT:** just like any laser rangefinder, the ability to accurately read distance will depend on the reflective characteristics of the object, as well as its size and ability to view it unobstructed. We suggest to measure distance 3 times for the same object to determine the most precise reading.

Your scope comes with rangefinder remote pressure pad, which can be utilized to turn the rangefinder remotely while scope is mounted on the rifle. To connect the remote pressure pad, remove the connector cover (6) and carefully connect the cord making sure the pin-holes align perfectly with the connector pins to prevent any pin damage. Once connected, tighten the wheel cover to keep the cord in place. Affix a small Velcro® patch on the pressure pad and affix it onto the area of the gun close to either hand

where it will be convenient to activate quickly, but without interfering with your ability to safely pull the trigger or operate firearm safety selector.

## **EXTERNAL POWER SUPPLY OPTIONS:**

---

It is possible to connect an optional external 5V power supply to the riflescope through the micro-USB-C connector (16) in order to operate it for a longer periods of time. The external power supply could be a common battery power pack, used to charge and operate your cell-phone and can be purchased online, or at your local electronics retailer. Please make sure only 5V power supply is used and output power should be at least 2A in order to reliably power up features like Video and Wi-Fi. To connect an external power supply, remove the safety cap (16) by unscrewing it counter-clockwise and either connect the micro-USB cable directly into the input, or (IF SUPPLIED WITH FACTORY USB ADAPTER AND CABLE) screw in the USB adapter and then connect the micro-USB side of the factory cable into the factory USB adapter and then connect the normal USB side of the factory cable into the USB output of your power supply. Once the external power supply is no longer needed, remove the factory cable and also remove the USB adapter and replace the metal safety cap before you take the unit to the field. Store the factory USB adapter and factory USB cable together in the carry case.

Additionally, you have an option of connecting an aftermarket external 9V power supply pack via jack (17). Make sure the external power supply jack dimensions and the Voltage matches.

## **CHOICE OF AIMING RETICLE AND ITS COLOR:**

---

Your thermal riflescope gives you a choice of 5 different aiming marks (reticles) to better aim during various conditions, distances and target sizes. To choose between the reticles enter the main menu by long-pressing the Super Controller (10). Once inside the menu, rotate the Super Controller counter-clockwise until “Reticle Type” is highlighted. Then short-press the Super Controller to enter into this setting. Once in the setting, rotating the Super Controller will select the type of reticle you prefer. To select the reticle color you must enter the main menu again and select “Reticle Color” setting. Once there rotating the Super Controller will give you 6 different reticle colors. Your settings of reticle and its color are automatically saved and will appear next time you turn on the scope.

## **ZEROING THE SCOPE:**

---

Once the scope is mounted onto a weapon, you must now “zero” it, or in other words, make sure the center of the aiming mark (reticle) is on the target during the shot. We recommend doing it at the established shooting range. You must follow all the safety rules, including knowing what's behind your target, at all times. To be able to effectively aim on the target, you must affix a heating patch (a small hand warmer patch is acceptable) to the back of the target in order to see the heat source when aiming (such

as commonly available hand-warmers, or similar patches that emanate heat once activated). As you are most likely to zero your thermal scope during daylight, it is useful to include a daylight spotting scope in this task, so that you can easily verify the shot groups without having to walk over to the target. **IMPORTANT:** always be careful not to point the scope front lens directly to the sun. We recommend doing this task on a cloudy day, or in such manner that the sun is not behind the target. Please remember to always cover the lens when scope is not in use.

Access the Main Menu by long-pressing the Super Controller (10). Now rotate the Super Controller counter-clockwise until you highlight "Zero the Scope". Now short-press the Super Controller to access this setting. The first screen will show horizontal arrows  $\leftrightarrow$  and numbers next to them. This is your WINDAGE adjustment. Make sure those numbers are all zeros. Now short press the Super Controller and vertical arrows  $\updownarrow$  will be shown along with the numbers. This is your ELEVATION adjustment. Make sure those numbers are also zeros.

If you zero at 100yds, aim at the center of the target and fire 1 shot, when both: vertical and horizontal numbers are all zeros. Observe the **Point Of Impact (POI)** on the target. Then, depending on the POI, begin adjusting the horizontal (windage) and vertical (elevation) directions by rotating the Super Controller. Switch between horizontal and vertical adjustments by short-pressing the Super Controller.

Once you start adjusting the clicks, you will notice the numbers changing. The left number will begin to change by one digit with each click, confirming the number of clicks you've made, while the right number will show the letter depending on the direction (L=Left / R=Right / U=Up / D=Down) and the number next to it. The number represents the distance in mm (millimeters) where the POI will shift at 100m/109yds with each rotation click.  $1\text{mm} = 0.04"$ . You will notice that with each click the number will change by 16mm, which equals approximately 0.63". This means that with each rotational click the POI at 109yds will change by approximately 0.63" in either direction. So if you need to change the POI by 10 inches to the left, you need to divide the number of inches (10) by POI change distance with each click (0.63") and you will need to make approximately 16 rotational clicks to the left.

Repeat the process until your POI is exactly at the center of the target.

You may use a ballistic calculator to calculate the desired POI at different ranges if, for example, you desire a 200 yard zero, which (depending on your particular cartridge/load) might mean the point of impact at 25 yards would be an inch below the point of aim, and the desired point of impact is 1.5" above the point of aim at 100 yards.

In such case, start at 25 yards and shoot one shot at the target. Using the zeroing adjustments (explained above) move the bullet strike toward the desired impact point 1" below the point of aim. Repeat this process until the bullet strike is an inch below the hold point. Then move the target to 100 yards and shoot three shots. Repeat the zeroing process by moving the center of the group to the desired point of impact 1.5" above the hold point. Repeat as necessary until the group center is 1.5" above the hold point. Move the target to 200 yards and shoot a 3 round group to confirm your zero. You may want to make another small change to your POI, but if your ballistic data was accurate and your 100 yard zero was exact, another adjustment at 200 yards most likely won't be necessary.

## **VIDEO / AUDIO RECORDING & STILL IMAGE:**

***Please see page-9 for video recording start options (Normal Mode and Quick Mode)***

To start video recording, press REC button once. Depending on the chosen recording mode the actual recording will start anywhere between 3 and 15 seconds from the moment the REC button is pressed. Once the counter starts the actual recording begins.

During video recording it is possible to take a still image (photo) by pressing the REC button momentarily. The image display frame will flash green confirming the image has been taken.

To stop recording press REC button and hold it for a little over 1 second. Words "REC Saving" will appear momentarily in the display – this is your indication that video recording has been successful and is saving on your scope' internal hard drive.

Should you encounter any error during recording, message ERR will appear with a number next to it (example ERR-74). In case of any ERR message press and hold REC button for 2 sec and it will exit the ERR mode and then you can re-start recording by pressing REC button again. If ERR message keeps re-appearing, please call us at 478-954-2721 or e-mail us at [FullMoonOptics@gmail.com](mailto:FullMoonOptics@gmail.com).

Please note your scope has an internal microphone that will activate during video recording. Please be aware that due to the scope housing made of aluminum and being completely sealed to provide water-resistance, the built-in microphone distance and sensitivity are greatly impacted, therefore the audio signal will be at its best only in the immediate proximity to the scope.

## **BAD PIXEL CORRECTION:**

**IMPORTANT: DURING ANY BAD PIXEL CORRECTION PROCESS YOU MUST KEEP THE LENS COVER ON AT ALL TIMES AND WE**



**STRONGLY RECOMMEND PLACING A DARK TAPE OVER THE PINHOLE IN THE LENS COVER. THIS IS NECESSARY FOR A COMPLETELY UNIFORM DARK SCREEN DURING THE PROCEDURE.**

Your device comes with a unique feature allowing you to manually correct any bad pixels that may develop during the course of time. To do that, press and hold Super Controller (10) to enter the main menu. Then rotate the Super Controller counter-clockwise until “Bad Pixel Correction” is highlighted. Then short-press the Super Controller to enter the pixel correction mode. The white crosshairs with flashing dot in the center will be displayed. Now you can rotate the Super Controller to direct the flashing dot to the bad pixel (to change between horizontal movement and vertical movement short-press the Super Controller. Once the flashing dot is over the bad pixel, press ZOOM button (14) and bad pixel will be corrected. You may need to press ZOOM more than once. Should you have a bad spot larger than one pixel, you must work each pixel one at a time, starting from outside pixels and then moving to the inside pixels. After all bad pixels are corrected, long-press the Super Controller until it enters Main Menu. NOTE: if you do not perform this function, bad pixel corrections will not be saved and you will have to perform the corrections again next time you start the scope. **NOTE: latest models come with Automatic Bad Pixel Correction function, which does the process automatically.**

**USB TRANSFER MODE: *Please read carefully!***

1. Power the scope.
2. Enter the main menu and select “USB Data Transfer to PC” (see also page-9) – **USB Transfer Mode turns OFF all other functions of the scope – it should only be used during actual data transfer.**
3. Remove the Micro-USB-C Connector cover (16).
4. Connect the micro-USB side of the cable to the Connector output. **We recommend using short length USB-C cable for faster and more reliable operation.** Take care during the connection to eliminate possibility of breaking the connector points. Do not use excessive force when plugging the micro-USB-C connector and never try to rock the connector from side to side during connection – this may break the connector points and render the USB connection inoperable. **NOTE:** broken USB connector is not covered under warranty.

**4a. IF SUPPLIED WITH FACTORY USB ADAPTER CUP AND CABLE** use the factory USB adapter cup and the factory cable for this task.

5. Connect the USB side of the cable to your computer.
6. Once the pop-up window appears, select “Open Files”
7. Transfer any video files you may have.
8. When finished you may keep the files recorded on the scope, or you may delete them from the scope storage to make space for new recordings.

9. **Always follow the safe connection exit by asking to eject the USB drive.**

10. Turn off device to exit USB Transfer mode

---

### **Wi-Fi VIDEO STREAMING (IF EQUIPPED):**

1. Enter the main menu and turn Wi-Fi on (see also page-8).
2. Follow Wi-Fi Connection instructions below for streaming.

### **Wi-Fi CONNECTION: *Please read carefully!***

1. Download **VLC app** on your smartphone or tablet (available for IOS and Android devices). For Android install **VLC for Android** version. For iOS install **VLC** version.
2. Power the thermal device.
3. Press REC button. Once the video recording counter starts working it is now possible to view the streaming video on your mobile device.
4. Now connect your mobile device to the thermal device:
  - a) On your mobile device – enter the Wi-Fi menu and find the serial number of your thermal device” – for example: “190001”. Select this connection. (Note: letters may not be engraved on your scope, but the number will match the serial number of your device).
  - b) Enter default password: **12345678**
  - c) **Make sure your mobile device is disconnected from the usual Wi-Fi signal (such as home or office), which it normally connects automatically, as it may cause interruptions in video stream.**
  - d) **Connection inside the buildings where multiple Wi-Fi signals are always present may not be reliable – if you are unable to connect inside your home or work office, please try it again when outside or outdoors where other Wi-Fi signals are scarce.**
5. Once mobile device is connected to the scope, open the VLC app and select “Stream” from the menu.
6. Enter this exact address: **rtsp://192.168.0.110** once prompted in the app and press Enter or click on the arrow mark, or click on “open stream”, whichever option is currently showing on the app.
7. For iOS smartphones – in the lower left corner you will find a miniature screen – click on this screen and it will open up full-screen.
8. In order to reduce the image streaming delay between the thermal device and the mobile device, you may need to reduce the cache level in VLC app settings.
9. NOTE: the video stream may not work reliably on older iPhone models (6 and lower) and Android (7.0 and lower) versions.

## **TROUBLESHOOTING:**

1. **Unit does not turn on:** please check if the batteries are inserted correctly or if they are fresh.
2. **Unable to obtain sharp and clear image:**
  - You may need to repeat the process of rotating the ocular and distance knob several times until you get a good feel of it
  - You may be viewing an object that is too close – the minimum focusing distance is approximately 3m or 9 feet
3. **Unable to see heat signatures behind visible barriers, such as glass:** THERMAL DEVICES ARE UNABLE TO SEE HEAT SIGNATURES IF THE OBJECT IS BEHIND ANY BARRIER THAT HAS REFLECTIVE NATURE, SUCH AS GLASS, THEREFORE YOU WILL NOT BE ABLE TO SPOT PEOPLE INSIDE A VEHICLE UNLESS THE WINDOWS ARE LOWERED DOWN, OR A PERSON STANDING BEHIND THE WINDOW IN A HOUSE OR IN SIMILAR SITUATIONS. LIKEWISE YOU WILL NOT BE ABLE TO SEE ANY HEAT SIGNATURES WHILE OBSERVING FROM BEHIND A WINDOW – YOU MUST HAVE UNOBSTRUCTED VIEW.
4. **Image appears to be washed out, especially the surrounding areas:**

You may be operating device in particularly humid conditions and need to increase either **GAIN**, or **IDE** functions (or both). Refer to manual pages 5 and 6.

## **WARNINGS:**



1. **NEVER** point this device directly at the sun or any heat source over 500 degrees Celsius (930 degrees Fahrenheit) even if the device is not turned on! Doing so will permanently damage the sensor with random light glare (similar to pictured here). Such damage is not covered by the warranty and will void any warranty claims. Always have the protective cover on the scope when transporting it during daylight, particularly during sunny days! Always transport your scope during sunny day pointed downwards, especially when mounted on the weapon.

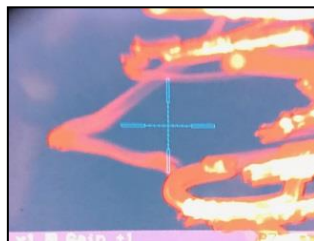

2. **NEVER** try to disassemble the unit by yourself or by anyone who is not our authorized technician. Doing so may result in injury and will void any warranty claims
3. **NEVER** leave the batteries inside the unit for a long period of time during extremely hot temperatures – the batteries may overheat, which may render the unit inoperable and will void the warranty
4. **NEVER** submerge the unit into water or use during heavy rain.

## TECHNICAL SPECIFICATIONS: *Genesis-40 (Genesis-55 / Genesis-75)*

Imaging Sensor	Hybrid Resolution 17µm with Image Enhancement
Frame Rate	50 Hz Shutter-free / NUC-free
Spectral Response	8-14µm
Image Display	1,024x768 Micro-OLED
Number Of Color Palettes	10
Optical Magnification	2.5x (3.5x / 5.0x)
Digital Zoom	2x & 4x
Focusing Distance	3m (5m / 7m) - ∞
Objective Lens Aperture	40mm (55mm / 75mm)
Field Of View	8.9° x 7.3° (7.5° x 5.6° / 6.5° x 5.2°)
Detection range (1.8m object)	1,000m (1,300m / 1,800m)
Laser Rangefinder max. distance	700m (763yds)
Video Recording Resolution	1024x768
Video File Type	.AVI
Power Supply	2 x CR123 Lithium / or 5V USB
Working time	2.5-3hrs (CR123 batteries)
Working Temperature Range	-10C / +50C /// 14F / 122F
Weight	780g (850g / 1,500g)

### FULL MOON OPTICS

136 Sewell Rd., Elko, GA 31025 (USA)

Tel: +1-478-954-2721 / +1-478-239-0099

E-mail: [FullMoonOptics@gmail.com](mailto:FullMoonOptics@gmail.com) Web: [www.fullmoonoptics.com](http://www.fullmoonoptics.com)

© 2021